



**karloskar**  
South Africa

# CENTRIFUGAL COMPRESSORS

Driving Centrifugal Technology to  
Exceed your Expectations



Oil & Gas



Iron & Steel



Chemical



Power



Food & Beverages



Pharmaceutical

## A Future Filled with Potential!

Kirloskar Pneumatic Company Limited (KPCL), founded in 1958, is one of the core companies of the Kirloskar Group of companies. A pioneer in compressed air and gas solutions that includes Air Compressors, Air Conditioning and Refrigeration Systems, Process Gas Systems, Vapour Absorption Systems and Industrial Gear Boxes, KPCL has grown over the last 60-years, driven by a rich legacy in manufacturing and industrial innovation.



kirloskar

With a strong global presence, KPCL's state-of-the-art facility in Pune undertakes research & development, manufacturing, assembly, testing, meteorology and other business processes. Focusing on continually evolving and developing our offerings, KPCL has led the way in developing sophisticated, hi-tech, future-ready products and solutions for further strengthening our long-standing relationships with our customers.

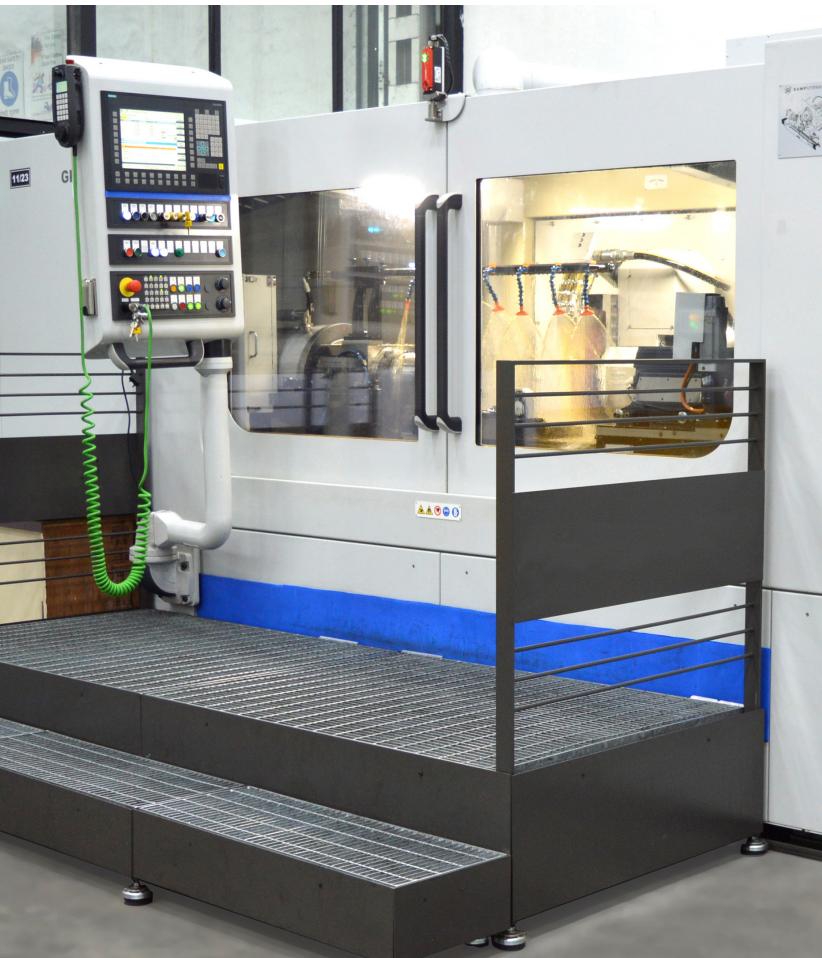

## Relentless innovation and **SMART FUTURE-READY, DEPENDABLE SOLUTIONS**

### In-House Technology and Infrastructure

State-of-the-art manufacturing facilities that consistently manufacture customer-centric solutions, support Kirloskar Pneumatic to deliver orders promptly and reliably. Our manufacturing facilities are ISO certified with equipment such as 5-axis CNC machines, grinding machines, CMM etc. that help maintain high precision and tolerance towards meeting the highest quality products under the supervision of an expert team. Our facilities are equipped to reduce delivery time, enhance processes and deliver quality and consistency, which ensure remote manufacturing and testing of world-class products by our customers.

## Applications:

### Iron & Steel



### Power



### Oil & Gas



### Pharmaceutical



### Chemical



### Food & Beverages



# Reliability, Efficiency and Productivity

## Inlet Guide Vanes (IGV): Controlling Your Capacity

- » Maximize effectiveness of turbo-compressors by regulating capacity and flow. As a standard, we provide electrically actuated IGV for capacity control
- » IGV creates a “pre-swirl” which increases first stage efficiency
- » With IGV, there is power saving in turndown compared to Butterfly Valve

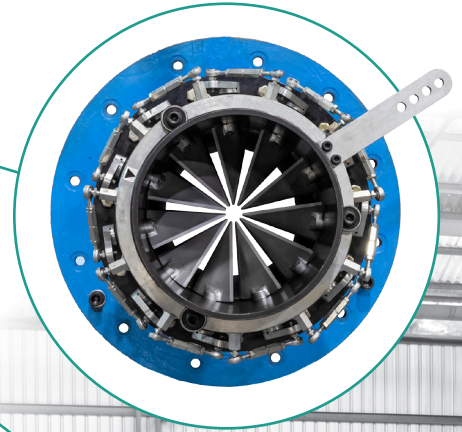

## Easily Accessible Gearboxes

- » Horizontally split gear casing
- » AGMA rated gears for minimum 20 years of service life
- » Easy for maintenance with lower downtime



## Thrust Bearings

- » Hydrodynamic tilting pad bearings
- » Radial bearings are provided on high speed pinion shaft
- » Radial cum thrust bearing are located on low speed bull gear
- » Thrust absorption at low speed ensures **lower mechanical losses** increasing efficiency
- » Low noise and wear

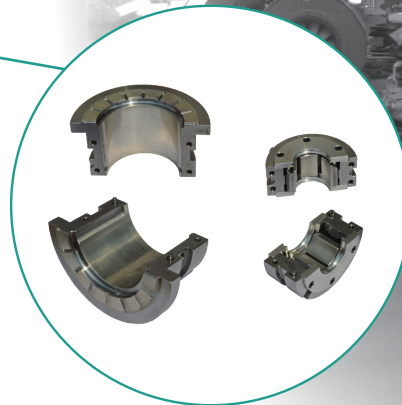

## Compactly Designed Inter and After Coolers

- » Pull-out type interchangeable tube bundle design offer high heat transfer efficiency
- » Easy cleaning with rod
- » Tube bundles MOC as per site requirements like stainless steel, Admiralty brass, copper, etc

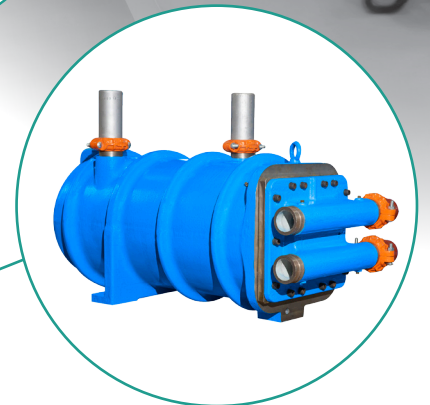

## An Aerodynamic Impeller: Driving Your Process

- » Impeller is a key part which helps to meet exact flow and pressure requirements
- » Backward lean: Higher turndown and rise to surge
- » Splitter blade construction provides balanced blade-to-blade loading and improves Aerodynamic performance
- » MOC Stainless steel - Corrosion resistant

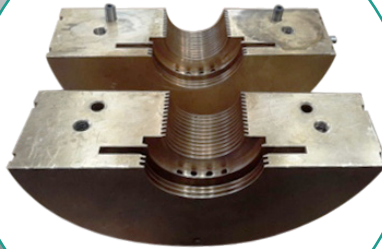

## Air-Oil Seals

- » Non-contact, non-wearing labyrinth air and oil seals ensure 100% oil free air
- » Easy replacement (split type)



# CENTRIFUGAL COMPRESSORS

to exceed your expectations

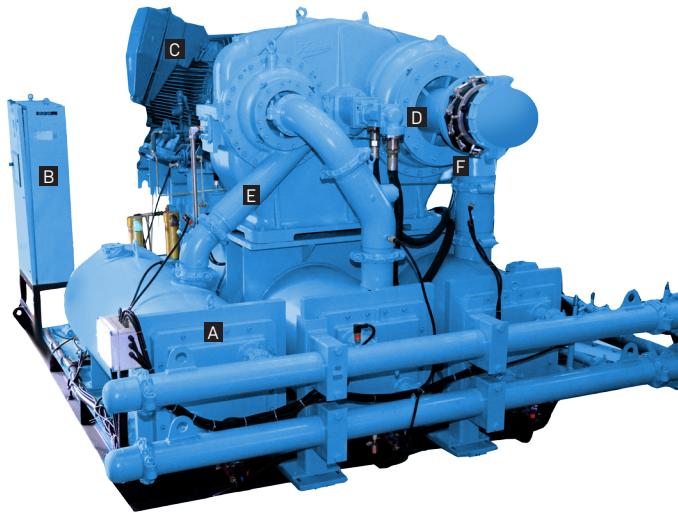

Our Centrifugal Compressors with integral geared technology are specifically designed to run at its optimum speed, resulting in less energy expenditure. These compressors have become vital and critical parts of multiple processes in varied applications. An efficient aerodynamic design makes these Centrifugal Compressors produce pressure by transferring energy to the air. The inlet guide vanes can be closed to reduce, and opened to increase the flow. A 100% oil-free air design is aligned to the exacting standard.

**A** - Compact Inter & After Cooler design with interchangeable tube bundle design  
**B** - Informative Controller

**C** - High efficiency Motor  
**D** - High efficiency Impeller & Diffuser  
**E** - Optimized Volumes

**F** - Accurate capacity & flow regulation through Inlet Guide Vanes

## Our Compressors Help You Save

### Saving is Earning

A versatile and cost-efficient solution, these compressors can be customized as per customers' requirements and are used across applications. Focused on power and energy efficiency, optimum process with cutting-edge technology, is what defines the compressors of the present times.



**12%**  
Maintenance



**12%**  
Equipment



**76%**  
Electricity

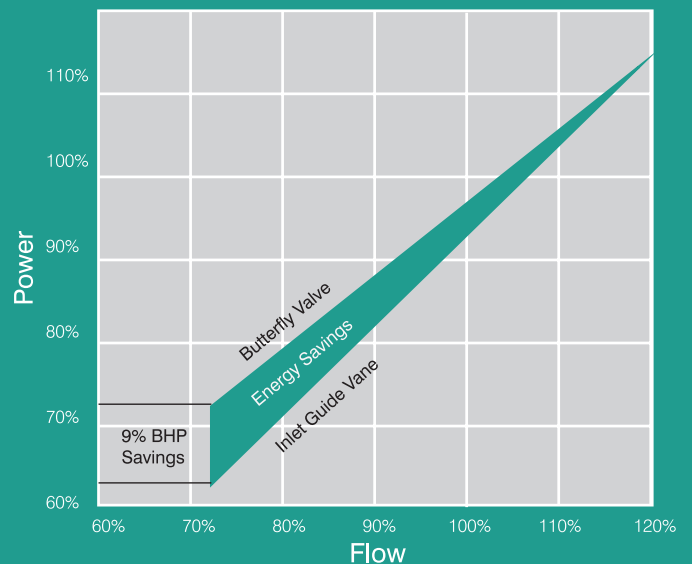

### Inlet Guide Vanes

IGVs used in these compressors, play very important role in efficiency of the compressor unit. IGVs are used to improve the overall efficiency of compressors. The benefit is seen when compressor throttles.

Helps you to save up to

**9%**

Energy over the life of compressor.

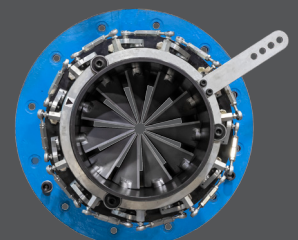

# 100% Oil-Free Air.



## Excellence in Reliability and Saving Energy.

Efficient aerodynamics make centrifugal compressors ideal for a variety of industrial applications. KPCL centrifugal compressor offers 100% oil free air to meet exact industry standards with minimum energy consumption.

KPCL centrifugal compressors feature a effective & reliable design that outperforms other compressors in delivering trouble-free operation and the lowest cost of ownership.

## The Energy Packed Machines



### HIGH PERFORMANCE AERO DESIGN

Aerodynamically designed with a backward leaning stainless steel impeller for best-in-class efficiency, the diffusers convert kinetic energy to pressure rise. Optimized volutes are present for effective pressure recovery.



### EASY MAINTENANCE

The horizontal split gearbox has easy access to bearings, seals and gears. There are removable tube bundle type intercoolers that are easy for inspection and cleaning. The pre-set preventive maintenance alerts with other features help in ease of maintenance.



### DRIVING DOWN OPERATION COST

With all the components designed to save energy, the centrifugal air compressors have excellent part load efficiencies and true unloading capability that allow a virtually infinite life of bearing with no wearing parts. This reduces the overall operation cost.



### SIMPLE INSTALLATION

Centrifugal Air Compressors are the most efficient and reliable air compressor that are available with pre-packages with after coolers, controls, drive motor and lubrication system. With a single water and electrical connection, the compact design makes it easy to install wherever required.



### TROUBLE-FREE OPERATION WITH WEB ENABLED ACCESS

The PLC based 'K-Logix' interactive touch screen Control System is another highlight of this compressor that allows remote monitoring and data trending.

# PLC PANEL FOR CENTRIFUGAL COMPRESSOR



## Compressor Control Systems

Kirloskar centrifugal compressors are equipped with 'K-Logix' control panel which is a PLC based adaptive control system. The built in the control system ensure safe operation of compressor. The high contrast touch screen LCD display make critical information quick and easy to access.

Web enabled remote management helps in monitoring and controlling the compressor remotely.

Real time data can be accessed via a PC or smart phone. You will receive emergency alerts on email and through SMS.

**Kirloskar**  
Pneumatic



# Cloud Based Remote Access

Access to serial or Ethernet interface of remote devices

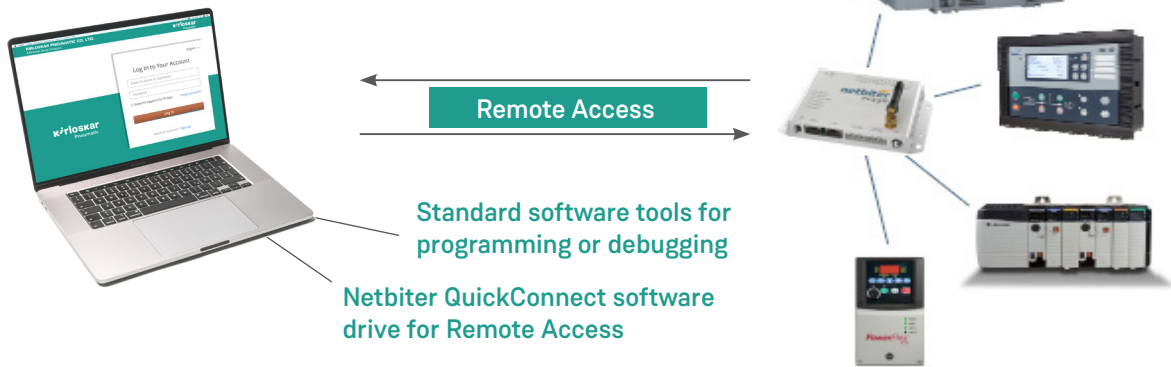

## Remote Management (Optional):

- » Monitor & control compressor remotely.
- » Single access point to all sites.
- » User & project Management.
- » View & download trend data.
- » Web connection – SIM/LAN/WAN.
- » Create & export data reports.
- » Emergency alert on email.
- » Emergency Alert on SMS.

## What you will get:



### More time

Reduce and optimize traveling (scheduled & emergency)



### Reduced consumption

Optimize use of machines, energy, staff, inventory etc.



### Improved quality of service

Improve service and charge more



### Fast ROI

A few service trips equals the cost of Netbiter gateway



### Reduced carbon footprint

Reduced travels by car etc. Monitor possible pollutions

# Flow Diagram

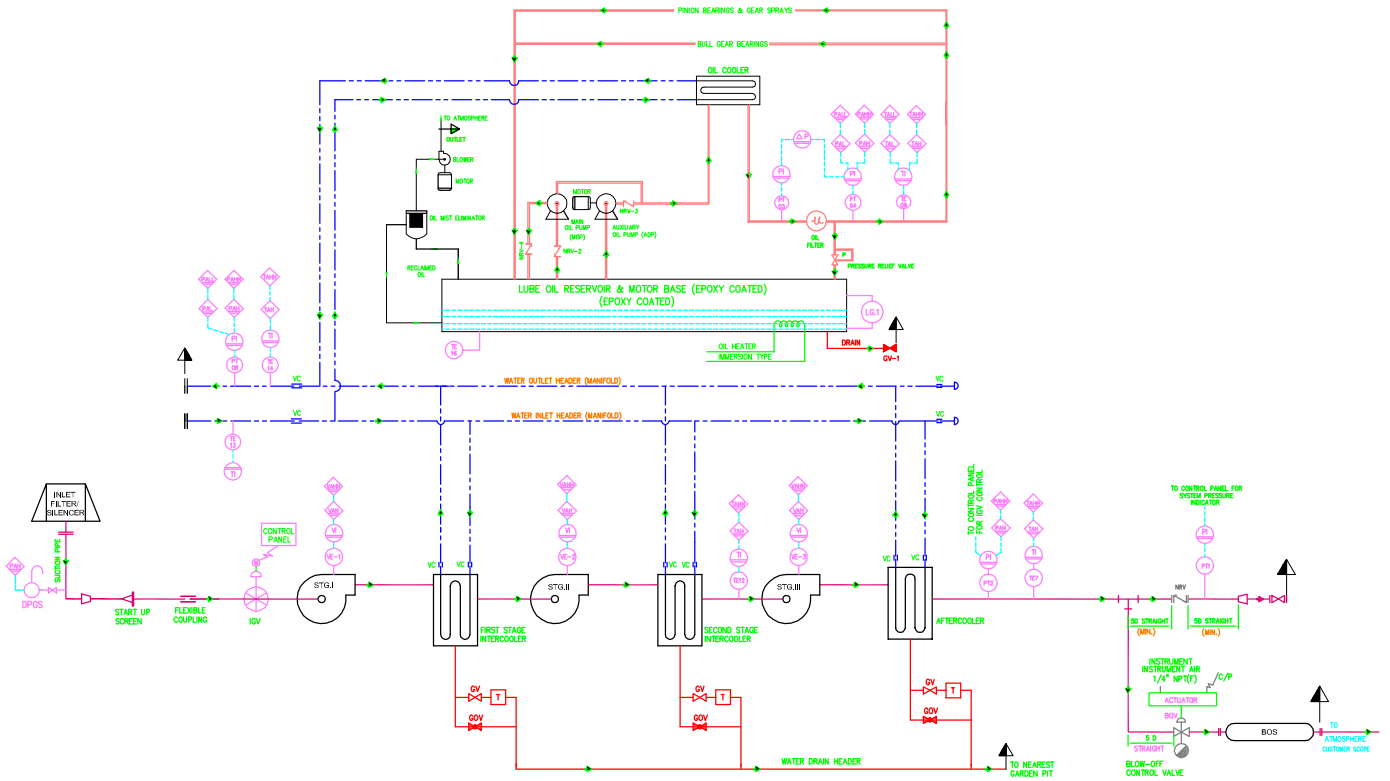

## Technical Specification

Model	Discharge Pressure	Capacity		Motor Rating		Weight Without Drive Motor		Dimension L x W x H
	barg	cfm	m <sup>3</sup> /hr	kW	hp	kg	ib	mm
A-2100	2.5-10.4	1200-2400	2038-4077	185-500	248-670	5000	11023	4800 x 2400 x 2400
A-3500	2.5-10.4	2400-5600	4077-9514	280-1000	375-1340	9000	19841	5550 x 3100 x 3200
A-7000	2.5-10.4	5600-8100	9514-13761	560-1600	750-2145	11000	24250	6000 x 3300 x 3400



Due to continuous engineering improvements, specifications are subject to change without prior notice. Products images displayed in this brochure are only for representation and may not exactly match the actual product.



## Service and Support

Our commitment ensures maximum uptime of the compressors and provides solutions to optimise them. Technology upgrades and energy audits are carried out by representatives to suggest the best energy conservation practices. We offer standard and customer specific service packages.

## Energy Audits

Certified KPCL representatives equipped with flowmeters, data loggers and other related audit instruments, undertake audit of compressed air plant and possibilities of energy conservation are suggested to customers.

## Training Programs

### Classroom:

In house training centre caters to requirements of training to customer's user and maintenance staff. These programs give complete information about the principles of operations of the compressors and maintenance practices.

### Onsite:

Training staff provides live demonstration in the factory premises and also provides training at customer works if desired by customer.

# After Market Support

At KPCL, we believe in an extended relationship with our customers far beyond the sale of the product. We support the product and its maintenance throughout its life. Our well spread dealer network all over India supports the maintenance of our products.

Our Air Compressor Division (ACD) provides aftersales service for products in warranty and out of warranty, through the Head Office which is wide spread across our network of branch offices, channel partners, and service franchisees. The spare parts division caters to the need of all spare parts of reciprocating compressors, centrifugal compressors, screw compressors, railway brake compressors and high-pressure compressors.

Training is provided at the client site location after commissioning of our compressor system. As per the agreement with clients, our Customer Training Center conducts seminars and service workshops for the client representatives at our Head Office.

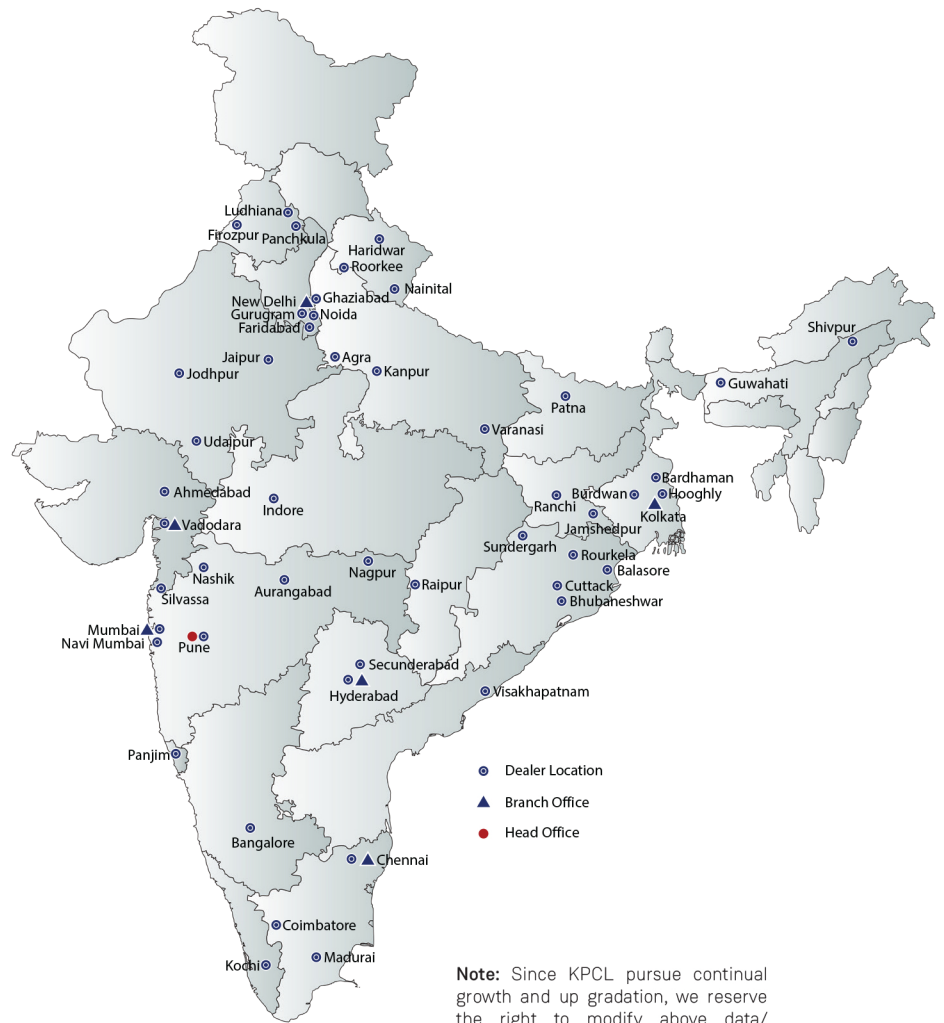

**Note:** Since KPCL pursue continual growth and up gradation, we reserve the right to modify above data/specifications in accordance with improved design

## **kirloskar** South Africa

### HEAD OFFICE

36 Rawbone Street  
Ophirton  
Johannesburg  
+27 (0) 11 493 3330  
reception@kirloskarsa.co.za

### LYDENBURG

9 Kerk Street  
Lydenburg  
+27 (0) 13 235 1874  
lydenburg@kirloskarsa.co.za

### RUSTENBURG

Shop No 12  
64 Beyers Naude Street  
East End  
Rustenburg  
+27 (0) 14 596 7591  
rustenburg@kirloskarsa.co.za